



SERENITY

LOOKS GOOD, SOUNDS GREAT

Serenity Fabric Decorative Panels



Serenity Fabric Decorative Panels are designed to absorb reflected sound (reverberation) that could otherwise cause sound problems in interior spaces. The fabric covered wall and ceiling panels provide excellent sound absorption while enhancing the décor of any room. Designers have the freedom to choose any stylish screen fabric wrapping from a huge variety available on the market.

Serenity Fabric Decorative Panels have been designed and tested in certified acoustic laboratories to ensure the sound absorption profiles for each panel thickness are quite predictable. Our a range of products will reduce reverberation, reflected sound and unwanted noise across all hearing frequencies of any public space including gymnasiums, call centres, restaurants, auditoriums and many more applications.

Features & Benefits

- These premium panels are fitted with L32 impact resistant membrane and MDF backing making them highly durable and suitable for high traffic areas.
- Simple installation to any internal wall or ceiling surface.
- Highly durable and robust panels making them ideal for high traffic thoroughfares.
- Manufactured in a range of sizes thicknesses to suit all interior applications or can be custom-made to size.
- Serenity Panels have been developed and fully tested in registered Acoustic Laboratories.
- Designers have the flexibility to remove panels as they don't have to be permanently fixed to the application.
- Available in a wide range of fashionable screen fabrics that enhance any interior décor.
- Fabric wraps around all edges and can be digitally printed if required.
- All Serenity components have low VOC content. Most have a substantial recycled raw material content.
- Serenity Panels are Ecospecifier listed.
- Fire Hazard Properties: Complies as a Group 2 Material. Ref: Specification C1.10a of the Building Code of Australia (BCA).
- Suitable for "Greenstar" and LEED" and similar environmental rating programs for commercial interiors.



Serenity Fabric Ceiling Panels are engineered and designed to reduce reverberation and create quieter & comfortable interior spaces. With a large assortment of sizes and finishes to choose from Serenity fabric ceiling panels are the perfect noise reduction solution.



Acoustic Performance

Sound Absorption Coefficients Reverberation room method (Hz)							
Thickness	125	250	500	1000	2000	4000	N.R.C.
25mm	0.15	0.55	1.00	0.95	0.95	0.95	0.85
50mm	0.26	0.71	1.03	1.11	1.09	1.03	1.00
75mm	0.50	1.05	1.05	1.00	1.05	1.00	1.05

Serenity Acoustic Ceiling Panels have been tested in N.A.T.A. registered laboratories at RMIT University using a full reverberation chamber test and have achieved Noise Reduction Coefficients (N.R.C.) as shown in the above table. The panels are tested with no air gap between the panel and substrate.

A NRC of 0.85 means that up to 85% of the sound that reaches the panel is absorbed. Increases in low frequency absorption can be achieved by adding an air gap behind the panel or by increasing the panel thickness.

Panel area and thickness will affect acoustic performance. It is strongly recommended that an Acoustic Engineer is consulted before specifying the requirements for a project.

Standard Panel Dimensions

Thickness (mm)	25,50,75,100mm
Panel sizes (mm)	1200 H x 600 W, 1200 H x 1200 W, 2400 H x 1200W Other sizes available on request Made to order shapes and sizes available

Typical Applications

- Schools, tafes & universities
- Restaurants & cafes
- Convention centres
- Multi-purpose facilities
- Commercial spaces



SERENITY

LOOKS GOOD, SOUNDS GREAT

Serenity Fabric Decorative Wall Panels

By using Serenity Fabric Wall Panels you can create comfortable and modern interior space. Serenity panels have been installed in studios, auditoriums and boardrooms through out the world with strong results in reducing sound reverberation.



Acoustic Performance

Sound Absorption Coefficients Reverberation room method (Hz)							
Thickness	125	250	500	1000	2000	4000	N.R.C.
25mm	0.15	0.55	1.00	0.95	0.95	0.95	0.85
50mm	0.26	0.71	1.03	1.11	1.09	1.03	1.00
75mm	0.50	1.05	1.05	1.00	1.05	1.00	1.05

Serenity Acoustic Ceiling Panels have been tested in N.A.T.A. registered laboratories at RMIT University using a full reverberation chamber test and have achieved Noise Reduction Coefficients (N.R.C.) as shown in the above table. The panels are tested with no air gap between the panel and substrate.

A NRC of 0.85 means that up to 85% of the sound that reaches the panel is absorbed. Increases in low frequency absorption can be achieved by adding an air gap behind the panel or by increasing the panel thickness.

Panel area and thickness will affect acoustic performance. It is strongly recommended that an Acoustic Engineer is consulted before specifying the requirements for a project.

Standard Panel Dimensions

Thickness (mm)	25,50,75,100mm
Panel sizes (mm)	1200 H x 600 W, 1200 H X 1200 W , 2400 H X 1200W Other sizes available on a request basis

Typical Applications

- Schools, Colleges & universities
- Restaurants & cafes
- Convention centres
- Multi-purpose facilities
- Commercial spaces

For more information visit www.sontext.com.au or contact Sontext or an Authorised Distributor



Head Office Australia / Vic State Office
 47 Longford Road,
 Epping, VIC Australia 3076
 T: +61 3 9432 2733
 E: sales@sontext.com.au

NSW State Office
 Level 13 Suite 1A 465 Victoria Avenue
 Chatswood, NSW 2067
 T: +61 2 9844 5414



Ceiling Panels

Serenity Fabric Ceiling Panels can be easily installed using conventional suspended ceiling systems such as a two way exposed T-grid System.

The panels can also be fixed using clips and track in a similar way to plasterboard, or even hung as described below.

Figure 1 shows Serenity Panels fixed directly to the ceiling using 'Rondo' metal furring channel and Direct Fix Clip #237.

When mounted with an airspace behind the panel, Serenity can be manufactured with a perforated backing to further enhance acoustic performance.

Figure 2 shows Serenity Panels suspended from chain to create a design feature. This gives the opportunity to either backlight the panels, or even incorporate lighting into the panels themselves—at the same time providing excellent noise reduction and improved sound quality in the space below.

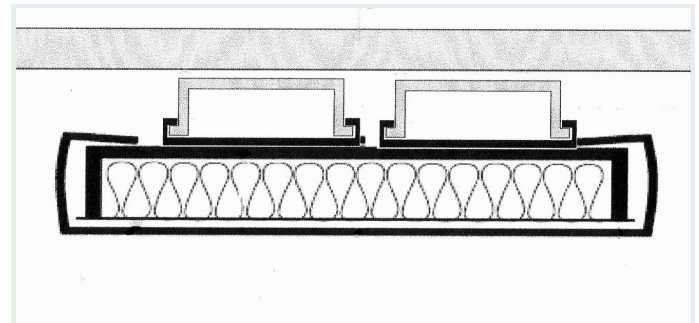

Figure 1

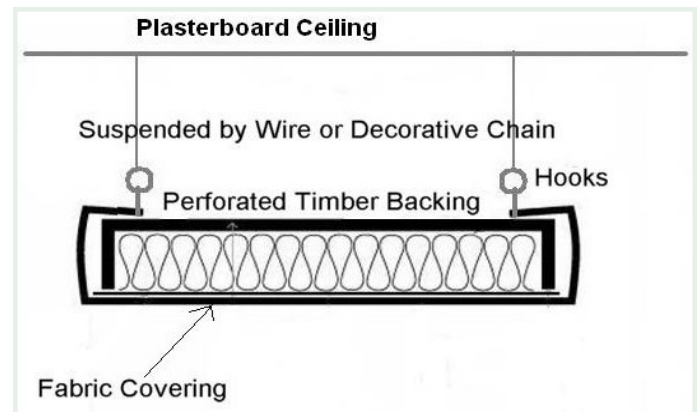
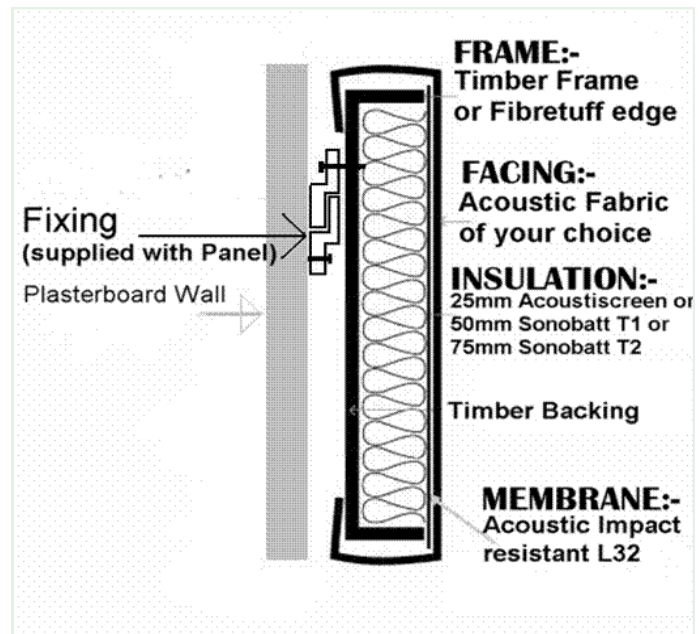

Figure 2

Wall Panels

Serenity Fabric Wall Panels utilise a metal "split batten" fixing system. One half of the system is applied to the back of the panel. The wall bracket section is supplied with the panels, and can be simply fixed to most wall surfaces with either screws or toggle bolts. Using this method installation time and costs can be reduced by 50% when compared to traditional methods. Alternative fixing methods are possible so you'll need to consult with your Sontext representative.

Serenity Panels can be installed by a carpenter or handyman, or by Sontext's own experienced installers if required.



For more information on how to install your Serenity Panels refer to Installation Guide.

For more information visit www.sontext.com.au or contact Sontext or an Authorised Distributor



Head Office Australia / Vic State Office
47 Longford Road,
Epping, VIC Australia 3076
T: +61 3 9432 2733
E: sales@sontext.com.au

NSW State Office
Level 13 Suite 1A 465 Victoria Avenue
Chatswood, NSW 2067
T: +61 2 9844 5414